

<b>Lesson 4</b>	Width and Length of Blades on a Wind Turbine		
<b>Level</b>	Key Stage 3	<b>Time required</b>	1 hour
<b>National Curriculum Links</b>			
Science, PHSE, Maths (view scheme of work for full details of links)			
<b>Aims</b>			
<ul style="list-style-type: none"> <li>Students will discover how the width and length of the blades can affect the efficiency of energy production</li> </ul>			
<b>Resources required</b>			
Pen, record sheet (one per group), blade template sheet (one per group), card (ideally 200 GSM), scissors, ruler, Wind Turbine Kit, electric fan, safety goggles			
<b>Web search keywords</b>			
Wind turbine blade length, wind turbine blade angle, wind turbine blade shape			

## Task

The students will experiment with different turbine blade widths and lengths and observe what effect this has on the voltage output. They will enter on the record sheet the blades width, blade length, and the voltage output.

Ask the students to set up the Wind Turbine Kit according to the instructions. Set up an electric fan (ideally 15" diameter) as described in the activity sheets.

Instructions are included with the Wind Turbine Kit. These can be downloaded in PDF format from: [http://www.ecostyle.co.uk/products/wind\\_turbine\\_kit/wind\\_turbine\\_kit\\_activity\\_sheets\\_v2.15.pdf](http://www.ecostyle.co.uk/products/wind_turbine_kit/wind_turbine_kit_activity_sheets_v2.15.pdf)

Once the fan is in position, do not move it or the Wind Turbine Kit. Ensure the fan is always used on the highest (fastest) setting. It is important to keep all these settings constant in order to achieve meaningful results.

For this experiment use a configuration of 3 turbine blades at an angle of 45°. Three of each size of cardboard blade inserts are required (24 in total). Either print off a paper copy of each sheet and use as a template to draw onto a sheet of card and cut out. Alternatively print three copies of each sheet directly onto card and then cut out the blades.

200GSM card will give the best result. Fold the shaded strip backwards and slide this into the turbine blade slot. The 'normal' size does not require a cardboard blade – this is the size of the plastic turbine blade.

## Risk assessment

Ensure the rotor blades are pushed firmly into the rotor hub. If the rotor blade spokes become loose, squashing the spoke slightly with pliers will achieve a tighter fit. Safety goggles should be worn by students operating the equipment and by those in the surrounding area.

# KS3 Lesson Plan

Record sheet

Blade Width	Blade Length		
	Normal (15cm)	Length A (20cm)	Length B (25cm)
Normal (2.5cm)			
Width A (3.5cm)			
Width B (4.5cm)			

# KS3 Lesson Plan

Blade insert templates (1 of 3)

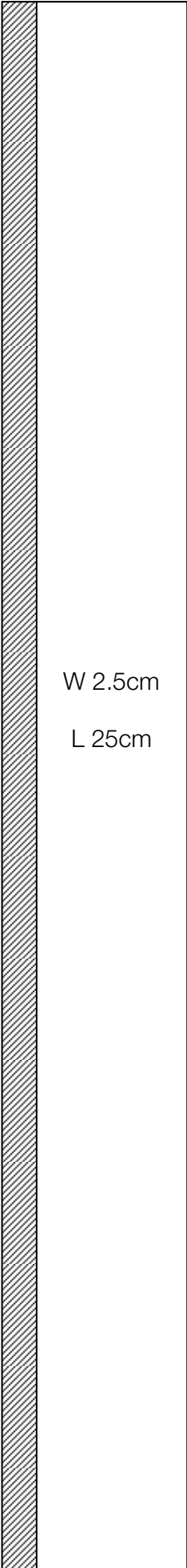
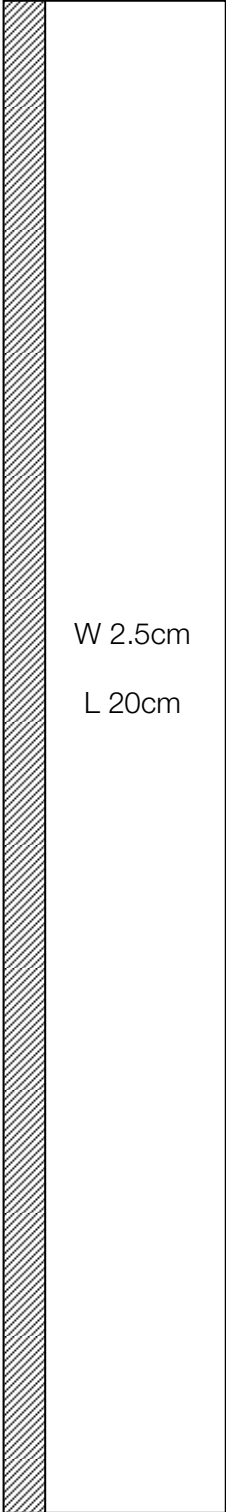

# KS3 Lesson Plan

## Blade insert templates (2 of 3)

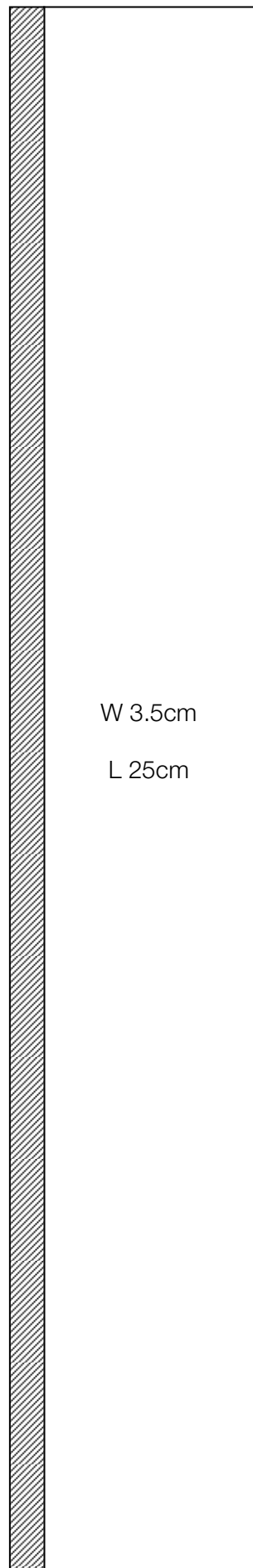
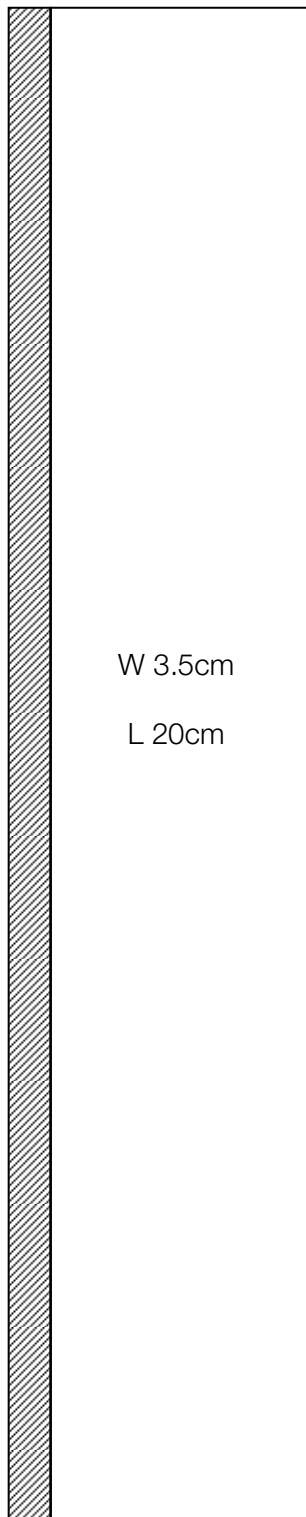
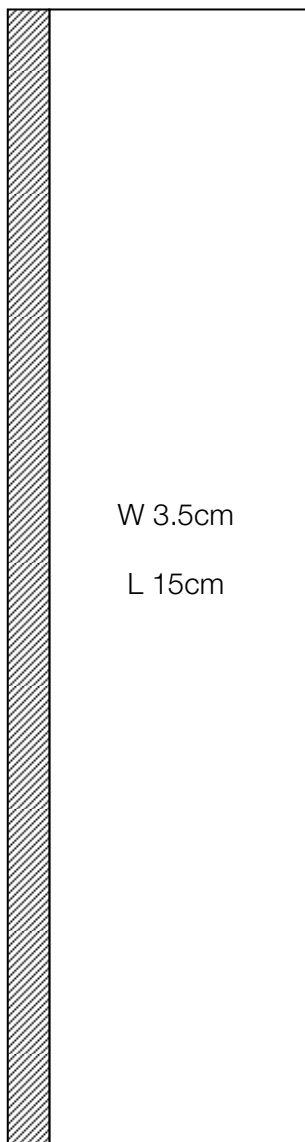

# KS3 Lesson Plan

## Blade insert templates (3 of 3)

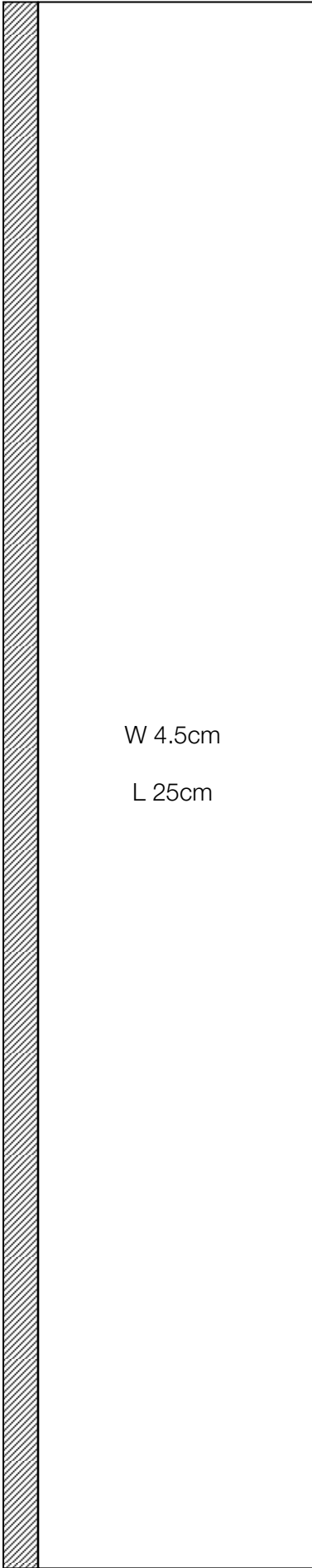
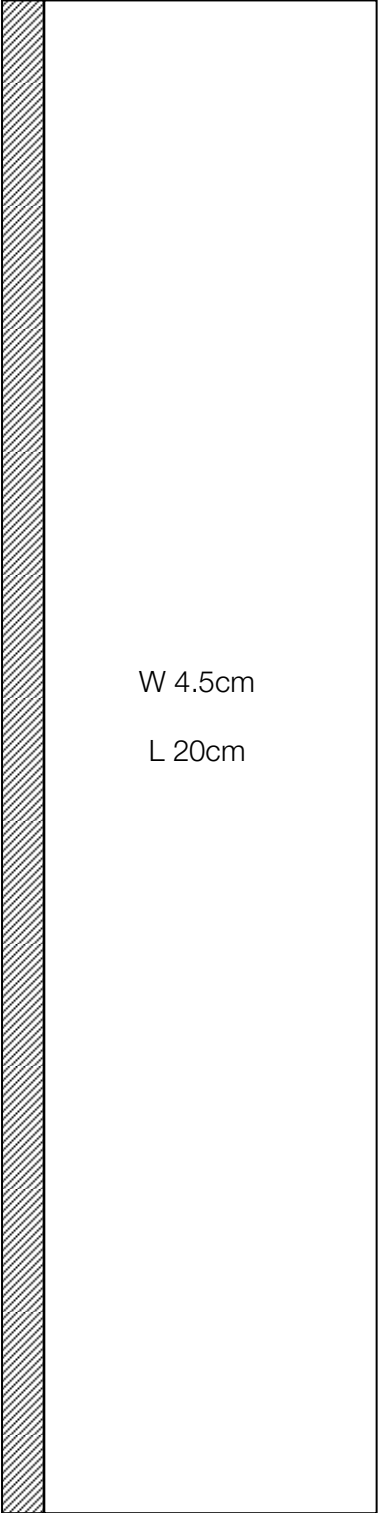
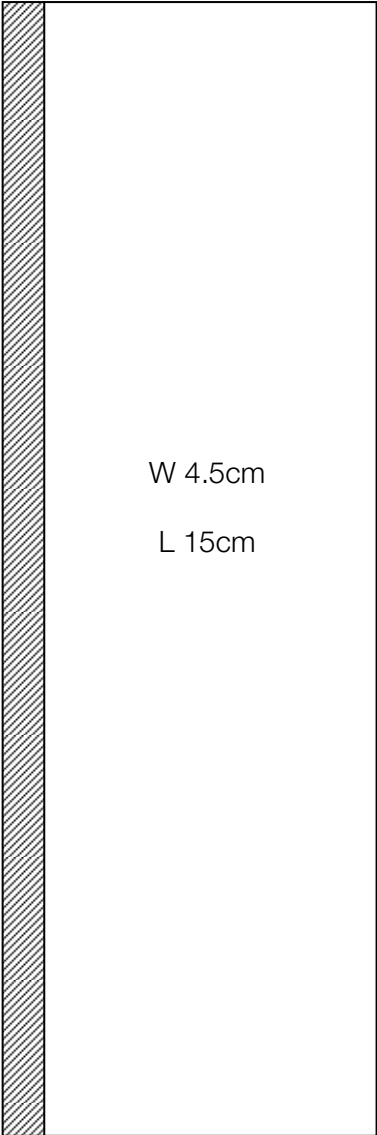

## Conclusion

- Discuss the students' results
- Which combination gives the most efficient energy production?
- Why do they think this setting gives the best performance?